

BIKE BRITE® Hydrofoamer

Model MC44 HF-481

Package Contains:

1. Injection molded container
2. Concentrate container
3. Suction tube/strainer
4. Spray gun with quick lid, including eductor disconnect assembly
5. Product information sheet

THANK YOU FOR YOUR INTEREST IN OUR PRODUCTS

Bike Brite supplies quality chemical proportioners. Please use this equipment carefully and observe all warnings and cautions.

*****NOTE*****

WEAR	protective clothing and eyewear when dispensing our Bike Brite motorcycle spray wash.
ALWAYS	observe our safety and handling instructions.
ALWAYS	direct discharge away from you or other persons or into approved containers.
ALWAYS	dispense Bike Brite spray wash in accordance with our instructions. Exercise CAUTION when maintaining your equipment.
CLEAN	equipment after each use in accordance with instruction sheet.
WEAR	protective clothing and eyewear when using this product, filling or emptying equipment or changing metering tips.
ALWAYS	re-assemble equipment according to the instructions. Be sure all components are firmly screwed or latched into position.
ATTACH	only to tap water outlets (85 PSI maximum).

Operation:

1. Unscrew foamer lid assembly from container.
2. Select a metering tip using the chart below as a guideline and press the tip firmly into the hose barb on the bottom of the lid assembly. Install the suction tube to the hose barb.
3. Fill the container with the Bike Brite professional strength formula using hand pump.
4. Screw foamer lid assembly securely onto container. Insert foamer lid assembly into female quick connect on spray gun

CAUTION: Foamer lid assembly must be securely fastened to container to prevent accidental spillage of concentrate during use of foamer.

5. Connect a garden hose with 3/4" male garden hose thread to the base of the spray gun handle. Turn on the water supply to the hose. (Minimum 25-PSI water pressure is required to operate the foamer.)
6. Grasp the spray gun handle in one hand and the foamer container in the other. Squeeze the spray gun handle to begin foaming. Continuous operation can be achieved by using the handle lock provided on the spray gun. Rinse by disconnecting the spray gun from the foaming lid assembly. Depress the black portion of the quick disconnect assembly to remove the concentrate container.

Metering Tip Selection:

Dilution ratios below were achieved at 40 PSI, cold water and water-thin viscosity (1.0 CP). Ratios will vary given PSI, water and ambient temperature, water flow rate and product viscosity. At water thin viscosity, the efficiency of the eductor is at its maximum with the black or gray tip. Removal of the foot strainer on the concentrate pick-up tube will also change these ratios. *If no tip is listed, the dilution ratio delivered falls between those shown.

Tip Color	Drill Size	Ratio	OZ/Gal
No Tip		12:1	10
Gray	30	12:1	10
Black	40	12:1	10
Beige	50	12:1	10
Red	55	12:1	10
White	57	14:1	9
Blue	60	16:1	8
Tan	65	18:1	7
Green	70	26:1	5
Orange	72	32:1	4
Brown	74	32:1	4
Yellow	76	42:1	3
Aqua	77	42:1	3
Purple	79	64:1	2
Pink	87	128:1	1

Troubleshooting

Problem	Cause	Remedy
1. Unit does not draw concentrate	a. Clogged suction tube strainer b. Metering tip orifice obstructed c. Water pressure too low d. Mineral deposits in barrel of foamer e. Clogged water inlet strainer (low water flow)	a. Clean or replace b. Rinse tip or replace: Do not attempt to clean - may alter size of orifice. c. Minimum 25 PSI required. d. Back flush unit. Remove container, suction tube and metering tip. Put finger over barrel opening. Apply minimal water pressure through garden hose at nozzle of barrel to be flushed. e. Descale foamer by soaking in weak descaling solution. f. Clean or replace strainer.
2. Weak foaming action	a. Clogged water inlet strainer b. Water pressure too low c. Water temperature too high	a. Clean or replace b. Minimum 25 PSI required c. Use lower temp water source. (Concentrate flow decreases above 140° F water)
If above steps fail to produce good concentrate draw and/or foaming action, replace lid assembly. See component chart below.		

BIKE BRITE® Hydrofoamer Parts List

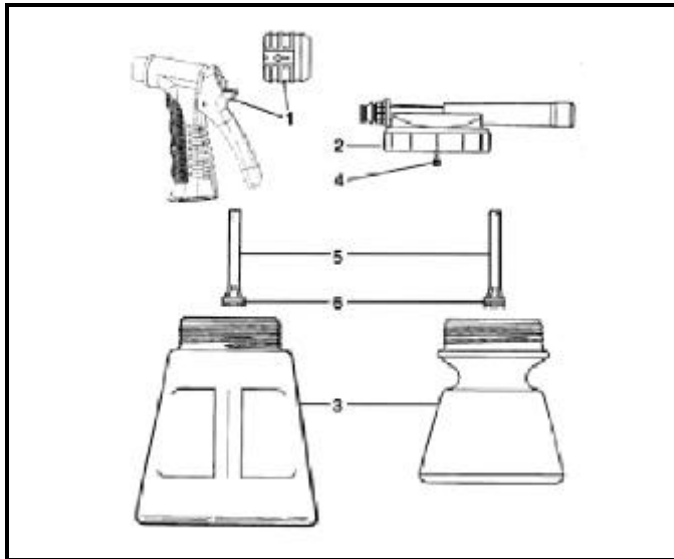

KEY	PART NO.	DESCRIPTION
1	688080	Spray gun & quick disconnect
2	688000	Foamer lid assembly
3	688201	Concentrate container
4	690009	Metering tips
5	500808	Suction tube, 8"
6	609600	Foot strainer

BIKE BRITE INC., 7177 Industrial Park Blvd., Mentor, Ohio 44060
 (800) 927-4833 / www.bikebrite.com/dealers